

CORNING

No Polish ST[®] Connector SM and MM, Flat Splice, 250/900 μm

P/N 78-0013-6978-0

Issue 3

related literature | [Search corning.com/opcomm](https://www.corning.com/opcomm). Click on "Resources/Standard Recommended Procedures."

INSTRUCTIONS

SAFETY PRECAUTIONS

Protective Eyewear

CAUTION

To reduce the risk associated with eye injury:
- Safety glasses should be worn when handling chemicals and cleaving the optical fiber.

Chemical Precautions

WARNING

To reduce the risk associated with fire:
- Storage, use and disposal of isopropyl alcohol should be per your company health, safety and environmental instructions. Refer to material safety data sheet for health hazards, safe handling, proper use and control measures.

CAUTION

To reduce the risk associated with eye or skin irritation from fiber gel in connector:
- Product contains phenylmethyl silicone (63148-58-3), hydrophobic silica (68611-44-9) and may cause minimal eye irritation. Avoid contact with eyes and wash hands before eating or smoking. Upon eye contact, immediately flush eyes with water while holding eyelids open and continue flushing for ten minutes. Contact a physician. Upon skin contact, wash with soap and water. Product information: Safety Data Sheet (SDS) or call Corning Customer Care at 800-743-2675.

Bare Fiber Handling

CAUTION

To reduce the risk associated with handling sharp glass fibers:
- Cleaved glass fibers are sharp and can pierce the skin. Use tweezers when handling shards and dispose of them properly per your company health and safety instructions.

Fiber/Cable Handling

NOTICE

To reduce the risk associated with fiber damage:
- Optical fiber can be damaged by excessive tensile, compressive and bending forces. Consult the manufactures' specifications for proper handling instructions. Laser Safety

Laser Safety

CAUTION

To reduce the risk associated with eye damage from exposure to laser light:
- Take the proper precautions when working with optical fiber because invisible laser light may be present. The principal laser hazard when working with fiber optics is injury to the eye. Never look directly into the fiber or connector using the naked eye or a microscope.

1.0 CONNECTOR AND TOOL DIAGRAM

1.1 The diagrams below show the parts of the No Polish ST[®] Connector (single mode pictured) and the No Polish ST Connector Assembly Tool 8835-AT. Please review these drawings to understand the instructions in the following pages.

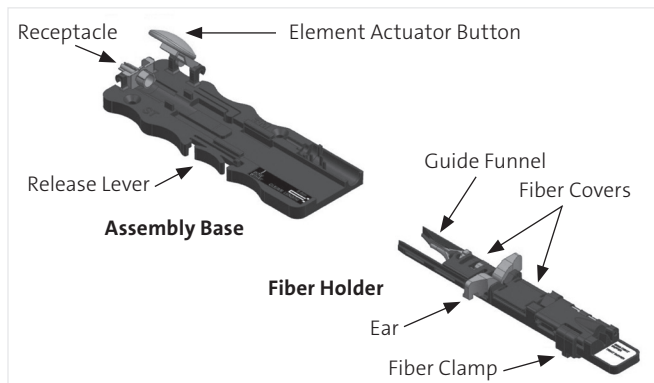
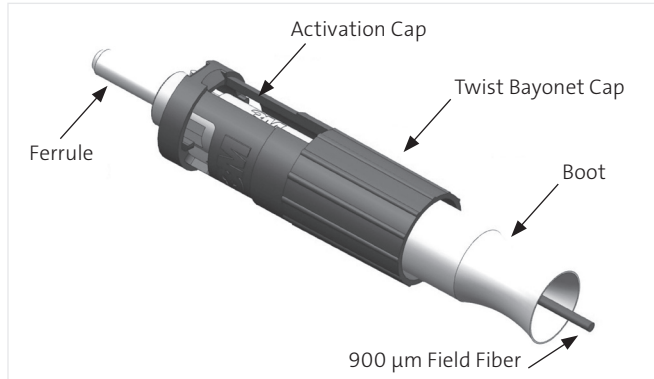

Note: Carefully follow safety, health, and environmental information given on product label or the Safety Data Sheet (SDS). For questions, call Corning Customer Care at 800-743-2675.

2.0 NO POLISH ST CONNECTOR SM AND MM 250/900 μm, TERMINATION INSTRUCTIONS

Note: To determine if a fiber is tight buffer or not, perform this test. Using a sample of the fiber and the fiber stripper, cut the buffer between 5 and 50 mm (.2 to 2 inches) from the end. Withdraw the stripper from the fiber. (Do not remove the cut buffer segment using the stripper.) Attempt to remove the cut segment of buffer from the fiber using only finger pressure. If the fiber is loose tube or semi-tight buffered, the cut segment will come off very easily. If it is tight buffered, the cut segment will be noticeably difficult to remove without the aid of a tool.

Note: When using loose tube or semi-tight buffered fiber, and after stripping and cleaving the fiber, it is important that the 250 μm acrylate coating on the bare glass not protrude more than 1 mm (.04 inches) beyond where the 900 μm buffer is stripped away. One way to help ensure this is to use the clamp on the fiber holder during the stripping process. Here's how. Place the fiber holder on the fiber facing backwards (clamp closest to cut end) and 20 cm (8 inches) from the end of the fiber. Secure the fiber into the SEMI-TIGHT BUFFER groove of the clamp. Proceed to strip the fiber as though it were tight buffered. Remove the fiber holder and proceed with the preparation and termination processes.

Another way to help ensure this is to use the clamp on a second fiber holder during the entire preparation and termination processes. Place the second fiber Proceed to strip, clean, and cleave the fiber as though it were tight buffered, and terminate the connector onto the fiber. Remove the second fiber holder from the fiber after the entire process is complete. holder on the fiber facing backwards and 20 cm (8 inches) from the end of the fiber. Secure the fiber into the SEMI-TIGHT BUFFER groove of the clamp.

2.1 Prior to each termination, clean all tools, including the fiber holder, with a lint-free cloth and reagent grade isopropyl alcohol.

2.2 Remove the dust cap from the front of the connector. Raise the actuator button on the assembly tool. Pivot the receptacle upward. Then insert the connector into the receptacle by aligning the key on the connector with the keyway in the receptacle and pushing it in until it stops. Move the pivot receptacle back to the horizontal position.

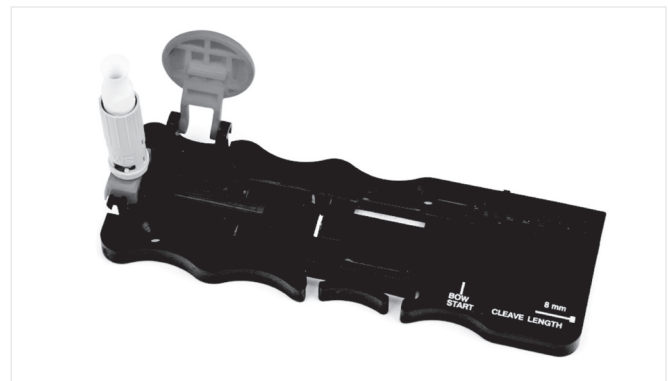

2.3 Move the guide funnel forward on the fiber holder until it stops; open doors and fiber clamp.

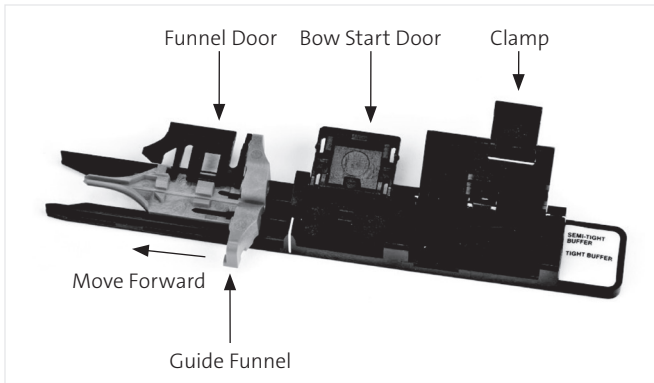

2.4 Strip, clean and cleave the fiber to 8 ± 0.5 mm ($.32 \pm .02$ inches) measured from the end of the $900 \mu\text{m}$ buffer. Use the cleave length marker on the assembly base to verify the length. Refer to the notes at the beginning of this section when using loose tube or semi-tight buffered fiber.

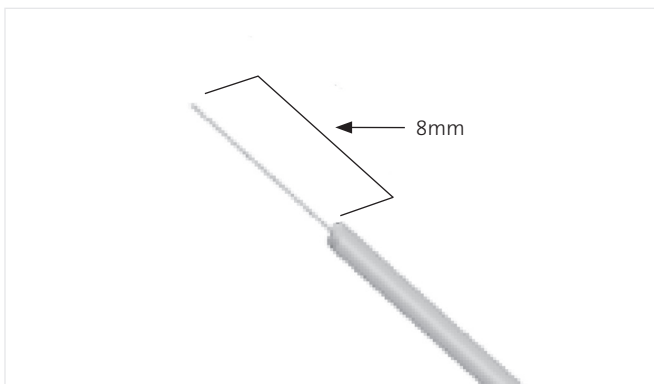

2.5 With the guide funnel fully forward, lay the fiber in the central groove along the length of the fiber holder as shown. Position it such that the stripped and cleaved portion extends slightly beyond the tip of the guide funnel.

If the fiber has a noticeable amount of curvature, orient it so the curvature is directed downward toward the fiber holder. In the clamp area of the fiber holder, place the fiber in the appropriate groove depending on whether it is TIGHT BUFFER, or SEMI-TIGHT BUFFER (loose tube).

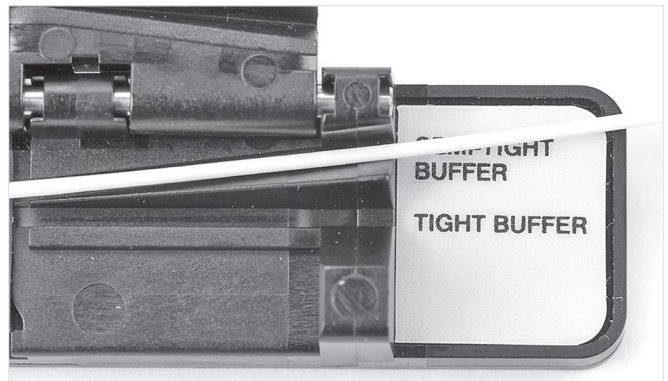
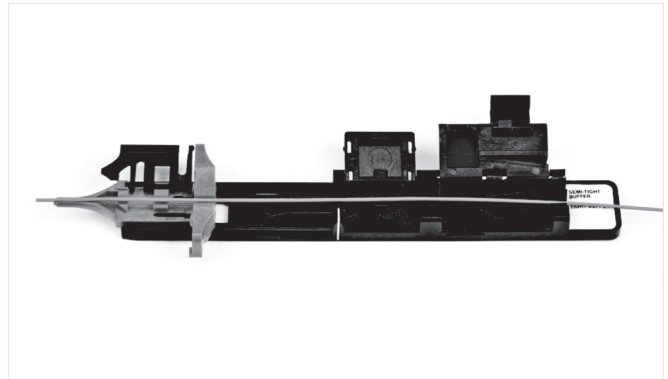

900 μm semi-tight buffer fiber

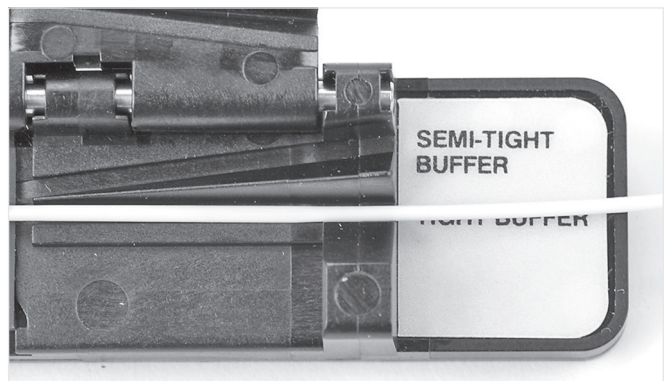

900 μm tight buffer fiber

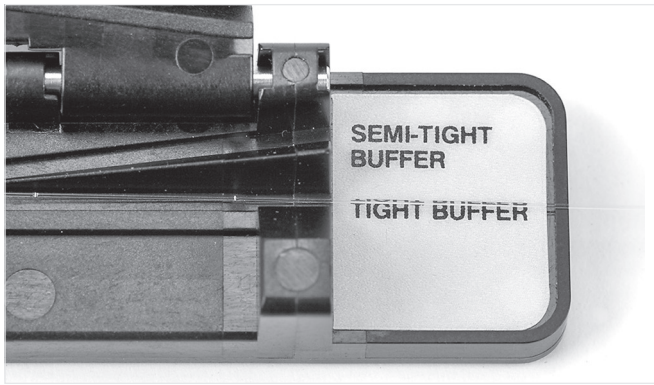

250 μ m fiber

2.6 Close the funnel door and bow start door on the fiber holder. Again ensure that the guide funnel is pushed completely forward to the end of the fiber holder. Pull the fiber back until the fiber tip is flush with the end of the funnel. To verify the cleave length is still correct, all coatings should align with the hole located in the funnel. Close the back clamp.

Note: For semi-tight buffer fiber, the 250 μ m coating may protrude up to 1 mm past the 900 μ m buffer. If necessary, re-strip, clean and cleave the fiber to meet length requirements.

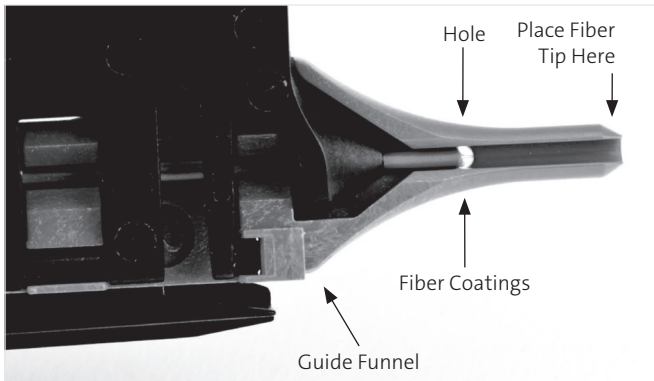

2.7 Place fiber holder in assembly base and slowly slide fiber holder forward, toward the connector.

Note: Allow 10 seconds for this movement from the time the fiber begins to enter the boot on the connector until the fiber holder bottoms out in the assembly base.

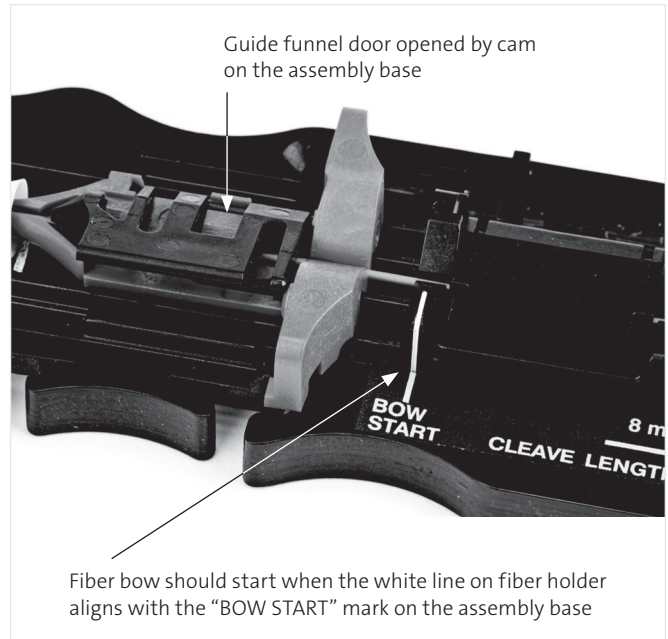
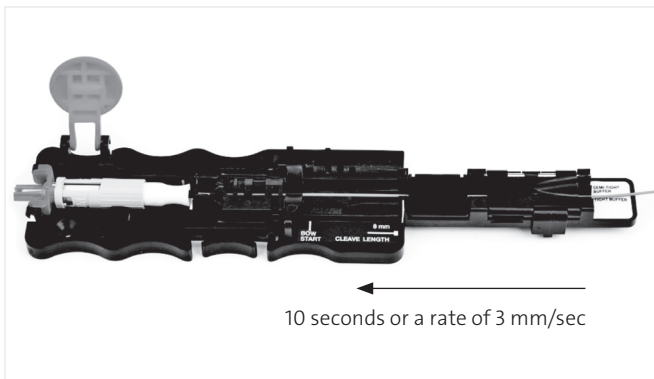

Fiber bow should start when the white line on fiber holder aligns with the "BOW START" mark on the assembly base

2.8 While slowly sliding the fiber holder toward the connector, a bow should start to form in the fiber when the white line on the fiber holder aligns with the white BOW START line on the assembly base. If a bow is not seen, slide the fiber holder back. If a bow is not seen, or if a bow is seen before the two white lines meet, slide the fiber holder back. Re-strip, clean and cleave the fiber, and begin the termination process again.

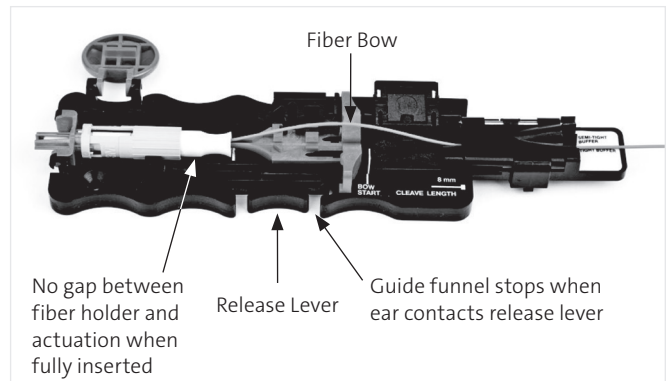

2.9 Continue to slowly slide fiber holder towards connector until it stops. Verify fiber bow again.

Note: The fiber will bow and lift the middle cover for rigid fibers and remain closed for 250 μ m and especially flexible 900 μ m fibers. This ensures proper fiber insertion force.

2.10 While maintaining the fiber bow, firmly press the element actuator button to actuate the splice element within the connector.

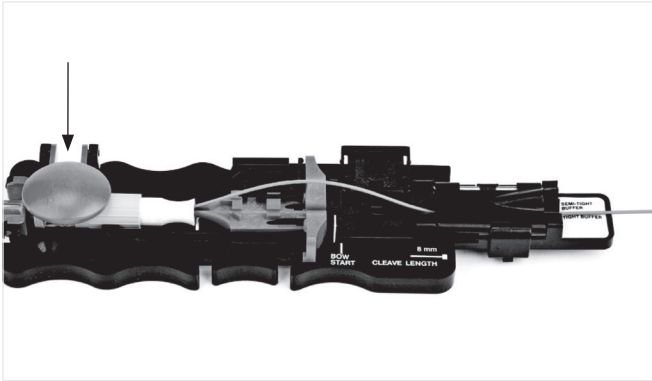

Note: *Never activate a connector without a fiber in it or with a fiber only partially inserted. Doing so will ruin the connector by blocking fiber from being fully inserted.*

2.11 OPTIONAL TESTING STEP: If the connector is to be tested and potentially reused, this needs to be done at this point in the termination process. To do so, carefully remove the fiber holder and connector from the assembly base by following steps 2.13 through 2.16. Use extra care when handling the connector and fiber as the 900 μm buffer has not yet been secured. The connector may now be tested. If the connector passes the test, reinstall it into the receptacle (2.2), reinsert the fiber holder into the assembly base being careful to avoid damaging the fiber, and proceed with step 2.12.

To remove the connector from the fiber, place it into the cap popper cavity on the assembly base oriented as shown. Then press down firmly using equal pressure at each end of the connector. This action will pop the element activation cap upward thereby opening the splice element. Separate the fiber and connector, and restart the termination process from the beginning.

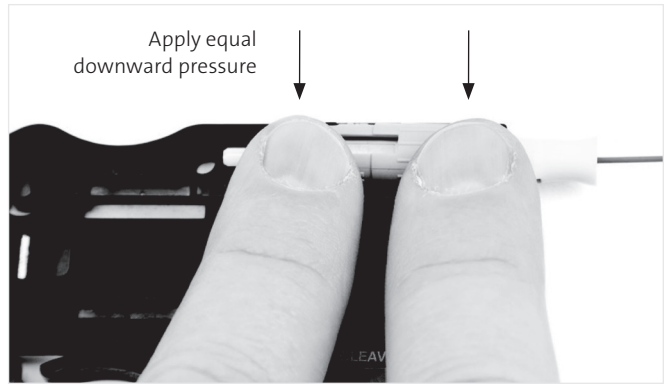
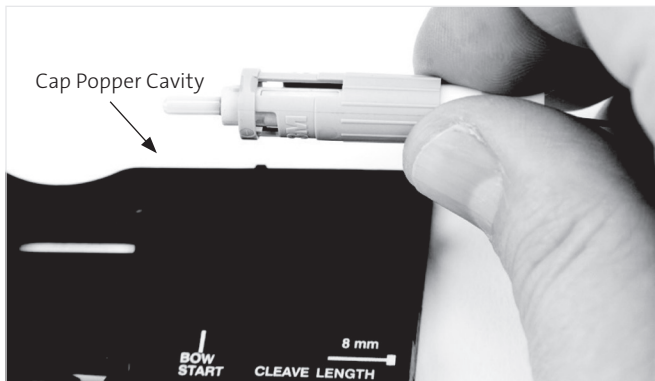

2.12 To activate the 900 μm buffer crimp at the rear of the connector, press and hold inward on the release lever located on the side of the assembly base, and push the guide funnel by the ears toward the connector until it stops.

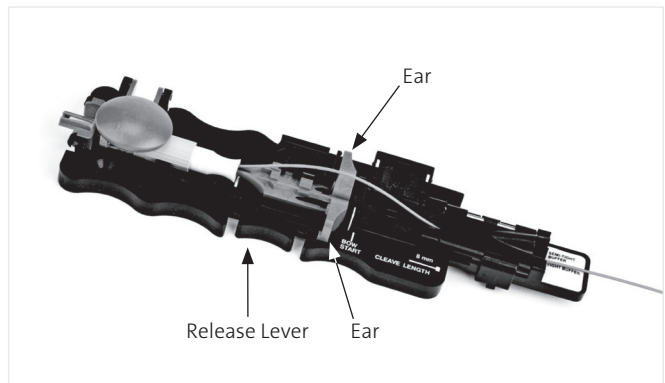

2.13 Release and lift the fiber clamp and raise the doors to release fiber.

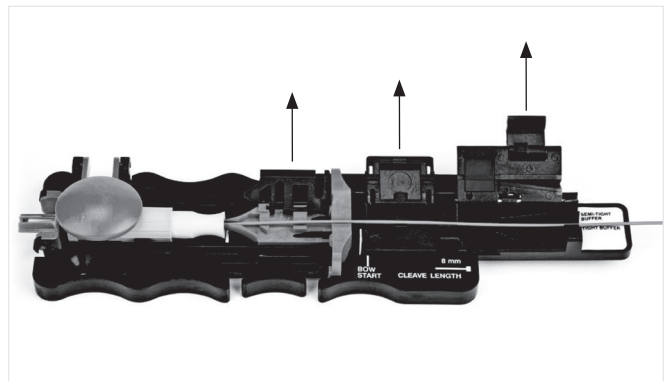

2.14 Slide fiber holder from actuation tool.



2.15 Raise the element actuation button.

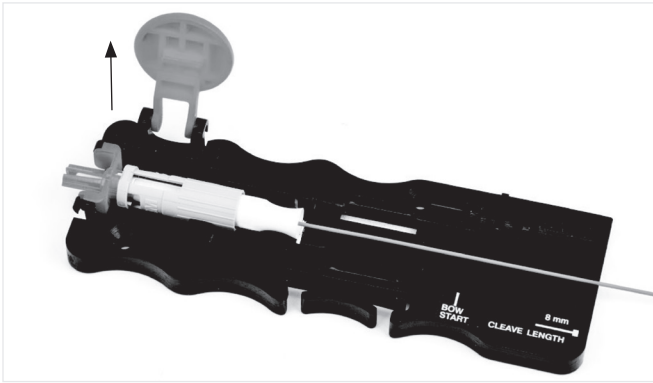

2.16 Pull connector from the receptacle.

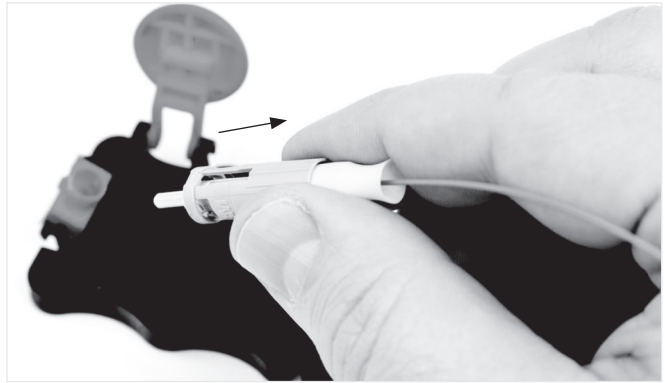

No Polish ST Connectors, Kit and Tool Descriptions		Packaging
8840	No Polish Connector ST® SM Plug 250/900 µm with tool (blue housing)	12 or 60/package*
6840-50	No Polish Connector ST MM 50 µm 250/900 µm with tool (black housing)	12 or 60/package*
6840-50/LOMMF	No Polish Connector ST MM 50 µm 250/900 µm LOMMF with tool (aqua housing)	12 or 60/package*
6840-62.5	No Polish Connector ST MM 62.5 µm 250/900 µm with tool (beige housing)	12 or 60/package*
8865	No Polish Connector Kit	1/package
8865-C	No Polish Connector Kit with Cleaver	1/package
8845-AT	No Polish Connector ST Assembly Tool	1/package

*"RoHS Compliant 2002/95/EC" means that the product or part ("Product") does not contain any of the substances in excess of the maximum concentration values in EU Directive 2002/95/EC, as amended by Commission Decision 2005/618/EC, unless the substance is in an application that is exempt under EU RoHS. This information represents Corning's knowledge and belief, which may be based in whole or in part on information provided by third party suppliers to Corning.

No Polish Connector Kit 8865-C with Cleaver
Kit Contents:
8865-AT No Polish SC Connector Assembly Tool 250/900 µm
8835-AT No Polish LC Connector Assembly Tool 250/900 µm
8845-AT No Polish ST Connector Assembly Tool 250/900 µm
2534 Fiber Cleaver (not included in 8865 kit)
6365-ST Stripping Tool
6365-KS Aramid Yarn Snips
Lint-Free Cloths (100/pkg)
Cleaning Alcohol Bottle



Corning Optical Communications LLC • 4200 Corning Place • Charlotte, NC 28216 USA
800-743-2675 • FAX: 828-325-5060 • International: +1-828-901-5000 • www.corning.com/opcomm

Corning Optical Communications reserves the right to improve, enhance, and modify the features and specifications of Corning Optical Communications products without prior notification. A complete listing of the trademarks of Corning Optical Communications is available at www.corning.com/opcomm/trademarks. All other trademarks are the properties of their respective owners. Corning Optical Communications is ISO 9001 certified. © 2019 Corning Optical Communications. All rights reserved.