

Wall mounting socket outlet switched and interlocked - 7 poles housing dimensions 225x118



Product description	
BALS-Prd.-Nr	16445
EAN	4024941164450
Product category	TE wall mounting socket outlet, switched, interlocked
Current	16A
Number of poles	7p
Arrangement of phases	6p+PE
Position of earth contact	9 h
Voltage	230V~

Product description	
Frequency	50/60Hz
Protection degree	IP44
Colour code	blue RAL 5015
Colour of appliance	Hinged lid blue RAL 5015, Housing screws grey RAL 7035, Housing bottom grey RAL 7035, Housing top grey RAL 7035, Control knob grey RAL 7035
Connection design	with screw terminal
Maximum conductor size	4,0 qmm
Cable entry	top entry M25/M25 bottom entry M25
Height	243mm
Width	118mm
Depth	137mm
Dimension of enclosure	225x118 mm (HxW)
Material of enclosure	Polycarbonate
Contacts	the contact carrier is made of high temperature resistant material, the contacts are brass nickel plated

Additional technical properties	
	The cable entry is one at top open, one at top is closed, and two at bottom are closed
	In 0-position lockable for 3 padlocks with bow diameter up to 7 mm

Logistics data	
Weight/pcs	1.18 kg / Piece

Logistics data	
Packaging	Carton
Content amount	1 ST
EAN	4024941164450
Length	275 mm
Width	175 mm
Height	137 mm
Weight	1.305 kg
Volume	5,737.5 ccm

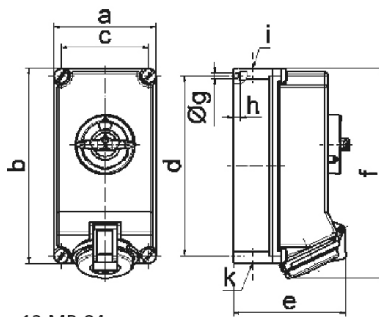

12 MB 84

Ampere	16	32					
Polzahl	7	7					
a	118,0	118,0					
b	225,0	225,0					
c	101,0	101,0					
d	208,0	208,0					
e	134,0	144,0					
f	242,0	251,0					
g ø	6,5	6,5					
h	8,0	8,0					
i	2 x M25	2 x M25					
k	2 x M25	2 x M25					