

Plug - with screwless terminals for harsh applications



Product description	
BALS-Prd.-Nr	210765
EAN	4024941145183
Product category	QUICK-CONNECT TE plug
Current	63A
Number of poles	5p
Arrangement of phases	3p+N+PE
Position of earth contact	6 h
Voltage	200/346 - 240/415V~
Frequency	50/60Hz

Product description	
Protection degree	IP44
Colour code	red RAL 3000
Colour of appliance	Pusher grey RAL 7035, Housing cover red RAL 3000, Collar red RAL 3000, Cable gland grey RAL 7035
Connection design	screwless spring-clamp technology with box terminals
Maximum conductor size	16,0 qmm
Cable entry	with cable gland
Height	234mm
Width	97mm
Depth	98mm
Material of enclosure	Polyamide
Contacts	the contact carrier is made of high temperature resistant material, the contacts are brass nickel plated

Additional technical properties	
	For cable diameter from 16 up to max. 36 mm, Screwless housing connection, MULTI-GRIP cable gland with gasket, integrated cable clamp and additional water evacuation openings

Logistics data	
Weight/pcs	0.72 kg / Piece
Packaging	Bag
Content amount	1 ST

Logistics data	
EAN	4024941145183
Length	98 mm
Width	97 mm
Height	234 mm
Weight	0.721 kg
Volume	2,224.404 ccm
Packaging	Carton
Content amount	5 ST
EAN	4024941946421
Length	325 mm
Width	217 mm
Height	210 mm
Weight	3.806 kg
Volume	13,588.4 ccm

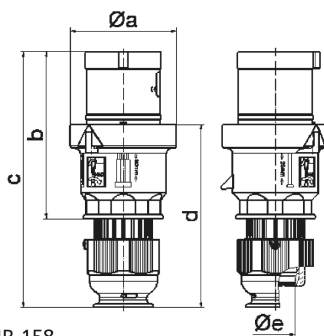

2 MB 158

Ampere	63	63	63			
Polzahl	3	4	5			
a ø	96,0	96,0	96,0			
b	153,0	153,0	153,0			
c	233,0	233,0	233,0			
d	167,0	167,0	167,0			
e ø	36,0	36,0	36,0			
Leiter mm ² min	6	6	6			
Leiter mm ² max	16	16	16			