

Plug - with screwless terminals for harsh applications



Product description	
BALS-Prd.-Nr	210764
EAN	4024941190015
Product category	QUICK-CONNECT TE plug
Current	63A
Number of poles	4p
Arrangement of phases	3P+PE
Position of earth contact	7 h
Voltage	480 - 500V~
Frequency	50/60Hz

Product description	
Protection degree	IP67
Colour code	black RAL 9005
Colour of appliance	Collar black RAL 9005, Bayonet ring grey RAL 7035, Cable gland grey RAL 7035, Housing cover black RAL 9005
Connection design	screwless spring-clamp technology with box terminals
Maximum conductor size	16,0 qmm
Cable entry	with cable gland
Height	234mm
Width	114mm
Depth	114mm
Material of enclosure	Polyamide
Contacts	the contact carrier is made of high temperature resistant material, the contacts are brass nickel plated

Additional technical properties	
	For cable diameter from 16 up to max. 36 mm, Screwless housing connection, MULTI-GRIP cable gland with gasket, integrated cable clamp and additional water evacuation openings

Logistics data	
Weight/pcs	0.72 kg / Piece
Packaging	Bag
Content amount	1 ST

Logistics data	
EAN	4024941190015
Length	114 mm
Width	114 mm
Height	234 mm
Weight	0.721 kg
Volume	3,041.064 ccm
Packaging	Carton
Content amount	5 ST
EAN	4024941946094
Length	325 mm
Width	217 mm
Height	210 mm
Weight	3.806 kg
Volume	13,588.4 ccm

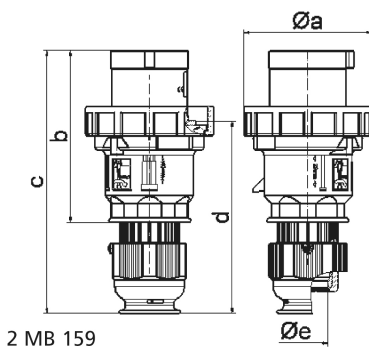

Ampere	63	63	63			
Polzahl	3	4	5			
a ø	113,5	113,5	113,5			
b	153,0	153,0	153,0			
c	233,0	233,0	233,0			
d	171,0	171,0	171,0			
e ø	36,0	36,0	36,0			
Leiter mm² min	6	6	6			
Leiter mm² max	16	16	16			