

DATENBLATT

DSUB Buchse, Schneid-Klemme, flache Bauform, EDFF 25 LP III/Z



Beschreibung

Gütestufe III. \geq 50 Steckzyklen.

Allgemeine Daten

Ausführung | Buchse

General data

Anschlussart | sonstige

Electrical characteristics

Kontaktausführung | weiblich (female)

Verfügbare Varianten

ArtNr.	Bezeichnung	Polzahl	Typ
29010.1	DSUB Buchse, Schneid-Klemme, flache Bauform, EDFF 09 LP III/Z	9	EDFF 09 LP III/Z
29011.1	DSUB Buchse, Schneid-Klemme, flache Bauform, EDFF 15 LP III/Z	15	EDFF 15 LP III/Z
29012.1	DSUB Buchse, Schneid-Klemme, flache Bauform, EDFF 25 LP III/Z	25	EDFF 25 LP III/Z

Zeichnungen

Dieses Datenblatt wurde maschinell am 24-02-2025 erzeugt. Technische Änderungen vorbehalten.



DATENBLATT

DSub Buchse, Schneid-Klemme, flache Bauform, EDFF 25 LPIII/Z

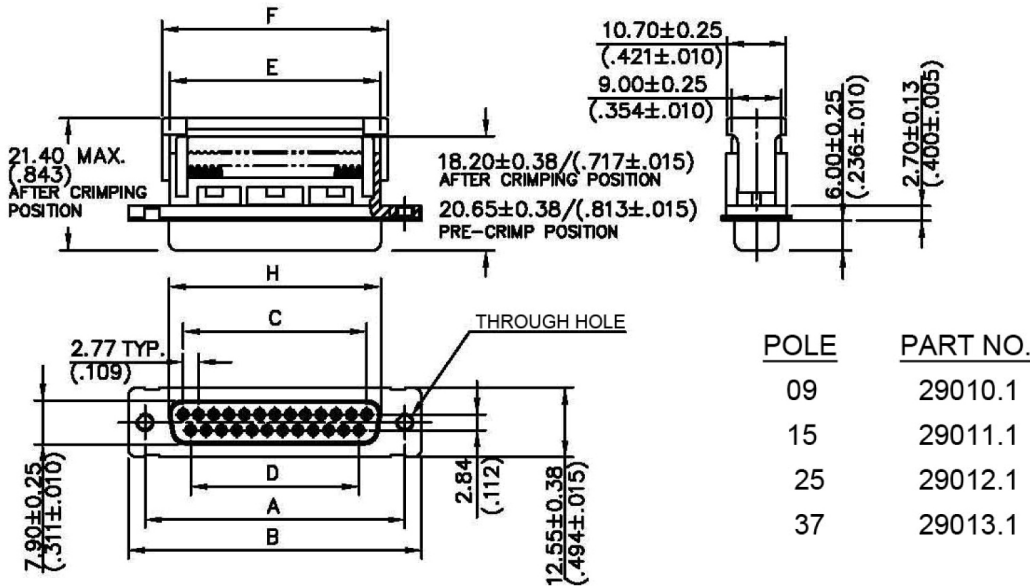

29013.1	37	63.50(2.500)	69.40(2.732)	49.86/(1.963)	47.09/(1.854)	54.60/(2.150)	57.10/(2.248)
29012.1	25	47.04(1.852)	53.08(2.090)	33.24/(1.309)	30.47/(1.200)	38.14/(1.502)	40.90/(1.610)
29011.1	15	33.32(1.312)	39.10(1.539)	19.39/(.763)	16.62/(.654)	24.00/(.945)	26.60/(1.047)
29010.1	9	24.99/(.984)	30.80(1.212)	11.08/(.436)	8.31/(.327)	16.10/(.634)	18.60/(.732)
CATALOG NO.	NO. OF POSITIONS	±0.13 A (±.005)	±0.25 B (±.010)	±0.13 C (±.005)	±0.13 D (±.005)	±0.25 E (±.010)	±0.25 F (±.010)

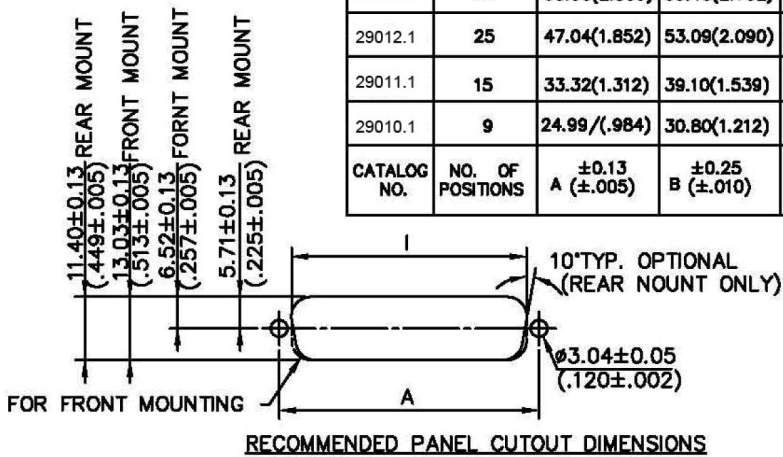

54.84/(2.159)	59.08/(2.326)	60.73/(2.391)
38.38/(1.511)	42.52/(1.674)	44.27/(1.743)
24.66/(.971)	28.80/(1.134)	30.53/(1.202)
16.33/(.643)	20.47/(.806)	22.20/(.874)
H ±0.25 (±.010)	±0.13/(.005) REAR MOUNTING	±0.13/(.005) FRONT MOUNTING

Dieses Datenblatt wurde maschinell am 24-02-2025 erzeugt. Technische Änderungen vorbehalten.

