

Cell Type N-2000CB

Specifications

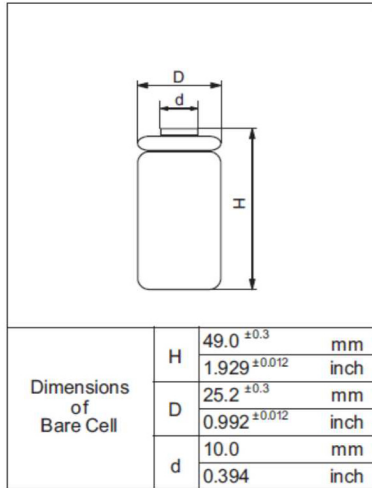

Nominal Capacity		2000mAh	
Nominal Voltage		1.2V	
Charging Current	Standard	200mA	
	Fast	600mA	
Charging Time	Standard	14 to 16Hrs.	
	Fast	4 to 6Hrs.	
Ambient Temperature	Charge	Standard	0°C to +70°C [+32°F to 158°F]
		Fast	10°C to +70°C [+50°F to 158°F]
	Discharge		-20°C to +70°C [-4°F to 158°F]
	Storage		-30°C to +70°C [-22°F to 158°F]
Internal Impedance (Av.) (at 50% discharge)		3.3mΩ (at 1000Hz)	
Weight		85g/ 3.00oz	
Dimensions(D)x(H) (with tube)		26.0 ⁰ _{-0.8} × 50.0 ⁰ _{-1.3} mm	
		1.02 ⁰ _{-0.03} × 1.97 ⁰ _{-0.05} inch	

Typical Characteristics

Charge

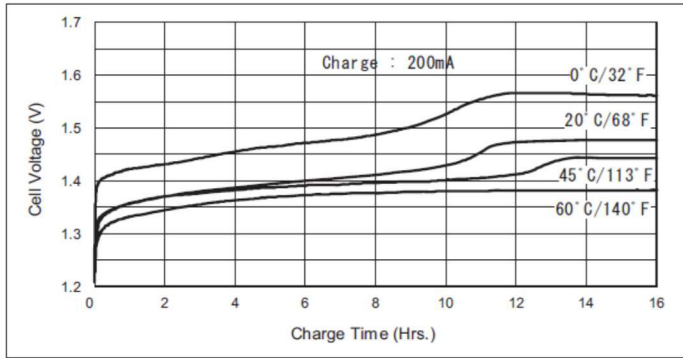

Discharge(at high rate)

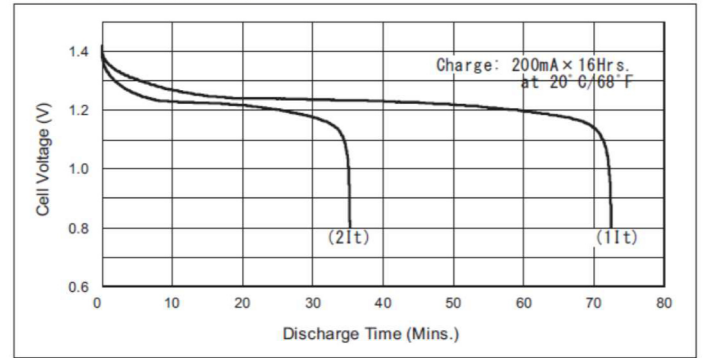

Cell Capacity(at various discharge rate)

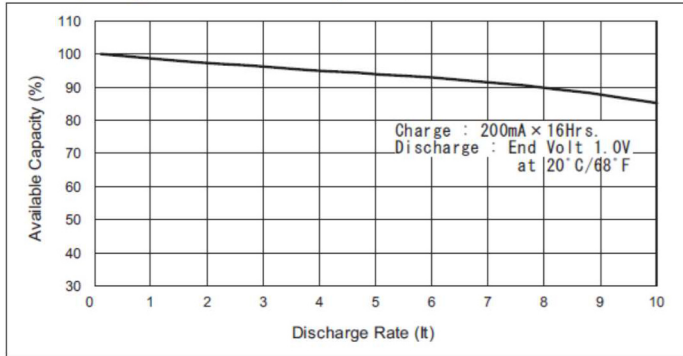

Discharge(at high rate)

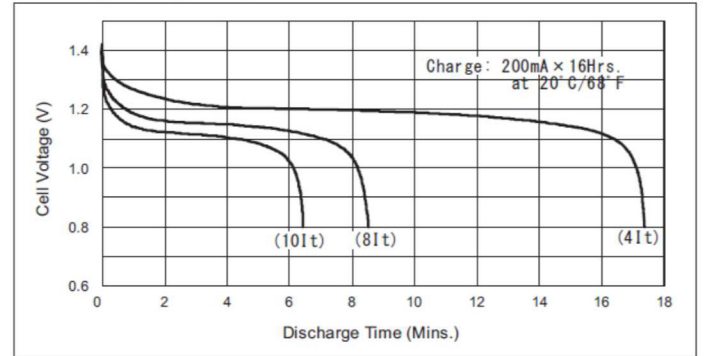

Discharge(at low rate)

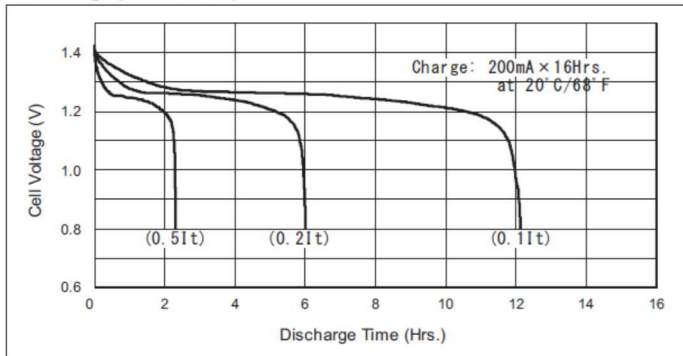

Temperature(Charge & Discharge)

